

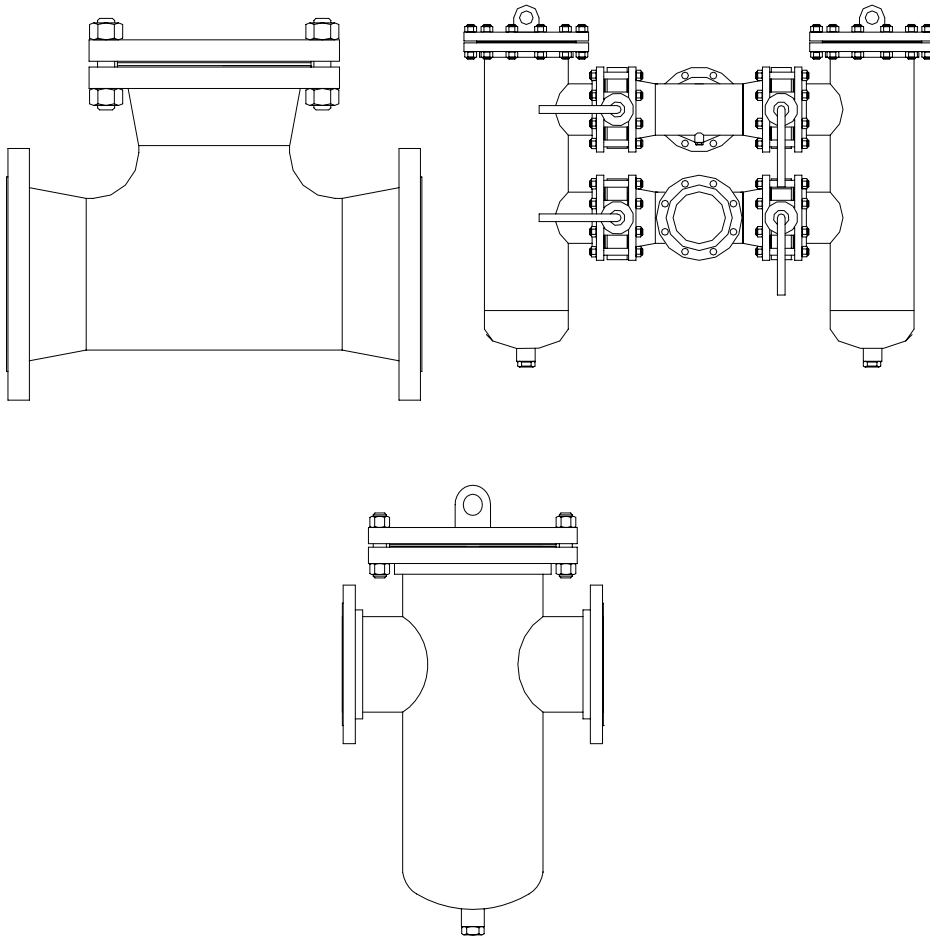

Installation and Maintenance Instructions for IFC Fabricated Strainers



Installation and Maintenance Instructions for IFC Fabricated Strainers

Strainer Installation Instructions

- Ensure all machined surfaces are free of defects and that the inside of the strainer is free of foreign objects.
- For horizontal pipelines, the strainer should be installed such that the blow-down connection is pointed downwards.
- For flanged end strainers, the flange bolting should be tightened gradually in a back and forth clockwise pattern. Threaded end strainers should use an appropriate sealant.
- Once installed, increase line pressure gradually and check for leakage around joints.
- If the strainer is supplied with a start-up screen, monitor pressure drop carefully.

Strainer Removal Instructions (Y, Basket, T and Duplex)

- Drain piping (For duplex strainers, isolate required chamber).
- Vent line to relieve pressure.
- Loosen cover and open to access screen. Remove, clean and replace screen in original position (Note: In some instances, a high pressure water jet or steam may be required for effective cleaning).
- Inspect cover gasket for damage. If necessary, replace. (Note: If spiral wound gaskets have been used, they must be replaced and cannot be used again).
- Tighten cover. The strainer is ready for line start-up

CAUTION SHOULD BE TAKEN DUE TO POSSIBLE EMISSION OF PROCESS MATERIAL FROM PIPING. ALWAYS ENSURE NO LINE PRESSURE EXISTS WHEN OPENING COVER.

Maintenance Instructions

For maximum efficiency, determine the length of time it takes for the pressure drop to double that in the clean condition. Once the pressure drop reaches an unacceptable value, shut down line (For duplex strainers divert flow to their chamber) and follow the "Basket Removal Instructions" above.

A pressure gauge installed before and after the strainer inline will indicate pressure loss due to clogging and may be used to determine when cleaning is required.

Trouble Shooting Guides and Diagnostic Techniques

- After pressurizing, inspect cover and other joints for leakage. Gasket replacement or cover tightening is necessary if leakage occurs.
- If the required filtration is not taking place, ensure the screen is installed in the correct position, that being flush to the upper and lower screen seating surfaces.

Limited Warranty

All products are warranted to be free of defects in material and workmanship for a period of one year from the date of shipment, subject to the limitations below: If the purchaser believes a product defective, the purchaser shall: (a) Notify the manufacturer, state the alleged defect and request permission to return the product. (b) If permission is given, return the product with transportation prepaid. If the product is accepted for return and found to be defective, the manufacturer will, at its discretion, either repair or replace the product, f.o.b. factory, within 60 days of receipt, or refund the purchase price.

Other than to repair, replace or refund described above, the purchaser agrees that the manufacturer shall not be liable for any losses, costs, expenses or damages of any kind arising out of the product, its use, installation or replacement, labeling, instructions, information or technical data of any kind, description of product use, sample or model, warnings or lack of foregoing. No other warranties, written or oral, expressed or implied, including the warranties of fitness for a particular purpose and merchantability, are made or authorized. No affirmation of fact, promise, description of product use or sample or model shall create any warranty from the manufacturer, unless signed by the president or vice-president. These products are not manufactured, sold or intended for personal, family or household purposes.

Manufacturer Information

Islip Flow Controls Inc.

Phone: (905) 335-8777 866-872-0072

Fax: (905) 335-0977 866-872-0073

Contact: Derek Islip-Contract/Sales Inquiries
Scott Islip- Engineering/Projects
Lee Spalding- Operations